

2ND ANNUAL

1980

*Traditional American
Music Festival*

Hiawatha MUSIC CO-OP



Champion, Michigan

Introduction

Welcome to the Hiawatha Music Co-op's Second Annual Traditional American Music Festival. We're expecting a lot of people, so to insure a good time for all we ask that you observe a few basic rules.

1. **EVERYONE MUST WEAR A TICKET BOTH DAYS.**
2. **Respect those around you, their property and their "final frontier."**
3. **NO PETS.**
4. **No frisbees in stage areas.**
5. **Remember, there are campers in the area. Please be quiet after 2:00 a.m.**
6. **Parents, be responsible for your children.**
7. **Please pick up your trash. Bags are available at the information table.**
8. **The information table in the pavillion will handle messages, lost and found, medical emergencies and other problems.**
9. **Any questions or problems? Ask one of the co-op workers in green T-shirts.**

People who cannot conduct themselves accordingly will be asked to leave. Several food and drink concessions are available to please your palate and local artisans will be demonstrating their crafts.

Thank you for your support and have **A REALLY GOOD TIME!**

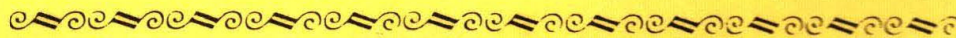

Thank-You!!

Special thanks to all of you who gave time, talent, energy and donations. To name a few: Sir Speedy and his crew — Don Lucas Imports — Champion Volunteer Fire Department — Dallas Cleaners — Dr. Zenti and his crew — J.R. Jilbert & Co. — WNMU Radio — Marquette Armory — Bunny Bread — Coca Cola Bottling Co. — L.R.N. Distributors, Inc. and Anderson Communications.

Hiawatha Music Co-op History

The Hiawatha Music Co-op was formed in January of 1979 by fifteen area citizens concerned with the preservation and promotion of Traditional Music. We were established with a lot of help and guidance from the Wheatland Music Organization and grew rapidly. Our very first efforts to raise much needed funds were carried out through bake sales and a lively basketball game between incorrigible Co-ops and the Munising Police.

March of 1979 brought not only our first long awaited concert dance but also one of the worst snowstorms in years. This didn't faze the hearty U.P.'ers who turned out by the hundreds, making the Co-op a viable organization.

Cold winds blew in again for our initial try at a festival at the Bay Shore Park in Munising in June, but warm hearts and hot licks kept us dancing for two days.

Last August 15th and 16th our First Annual Traditional Music Festival was a rousing success! Those of you who were able to gather with us will remember also the fine music, food and fellowship we all enjoyed. Workshops and concerts featured such nationally known musicians as The Fiction Brothers, Dakota Dave Hull and Sean Blackburn, Mike Seeger and Art Thieme. The overwhelming response of this festival has brought us national acclaim in *Sing Out!*, a folk music magazine and has made us financially secure enough to branch out into other areas.

We have been able to partially fund the Living Folk, a traditional music education trio from the Lansing area to spend a week in our area schools through Project Stars; and this winter a Student Chapter of the HMC was formed to present traditional music on the campus of Northern Michigan University. Two concerts this spring featured Sally Rogers and The Red Clay Ramblers.

The Co-op is now a registered non-profit corporation, and as of Summer, 1980, our membership has grown to over 150 volunteers.

Plans for the future include a four-concert series this fall at NMU and a joint concert with PAAC at the Vista Theatre in Negaunee. (See the calendar at the back of the program.) Possibilities for the future include more area school programs, a traveling road show through U.P. libraries, and additional regional Co-op Chapters.

The festival and all events are made possible by the volunteer work of our members; but the success of these events and the growth of future ventures of the Co-op all depend on you, the audience. Thank you much for your participation and invaluable support!

Information Table

This table, located in the pavillion between the kitchen and restrooms, is the Headquarters for the Festival. Here, you can get information about the music co-op, pick up newsletters or a program, leave messages, buy tickets, T-shirts, and performers' albums, sign up for our mailing list, inquire about lost and found items, and pick up trash bags or anything else you may need.

Local & Regional Performers

The Boreal String Band

Representing "Marquette's Premiere String Band for the '80's", are: Steve Sleight on fiddle; Mark Havlena - Fiddle and guitar; and Jim Sigler - stringbeans/shoestrings/anything with strings. Scheduled to be rejoining them is John Warstler on guitar and vocals, who departed in June to move downstate.

At this time we would like to thank the Boreal String Band for the "open mike" set-up provided between sets and their Thursday night gigs at Fathers/Little Italia. It has provided a real "spring-board" for up-and-coming local talent.

Close to the Floor

Made up of mandolinist Mike Nowlin, and guitarist Mike Cohen - both veterans of the QUASIMODAL and LIMESTONE string bands - as well as fiddler, Lee Haydon, and Tim Clancy on accordion, whistle and guitar, this new group made its debut at the 4th Guild Hall Dance last June. Featuring instrumental dance music of Irish/Scandinavian/French-Canadian/ and Appalachian origin, they structure their sound around the use of the concertina, which they regard as their hallmark.

The Cracklin' Sap Stompers

Makers of fine jug-band-style music from everyday laundry and kitchen utensils; the Stompers show no fear whatsoever in their selection of material - lending an overall "Frankensteinian" quality to their repertoire. Its members are: Dee/Lana Hough on washtub bass/guitar and mandolin; Dave/Pam Bett on guitar and uke/washboard and kazoo; and the inimitable Kurt Craig - "Maestro of the Spoons".

Bear Creek

This group - another of the for-real bluegrass bands we're presenting this year - has been plying its trade in the Escanaba area for awhile now. Coming up for their first H.M.C. engagement, BEAR CREEK is made up of Bruce Irving on banjo; brother Mark Irving on bass; Gary Aho on mandolin; and Rick Demsky on guitar.

Julie Saccone

A performer who has been around the Marquette folk scene for quite a while, Julie appeared (without billing) along with John Warstler at the Hiawatha's first concert in March of 1979. Now appearing for the third time under our banner, Julie's songs are all exquisite choices from the offering of folk and contemporary sources, delivered in her very own delightfully delicate style.

Mel Kangas

Mel's instrument is the kantele - a table harp of Finnish origin - the haunting sound of which serves to remind us of the wealth of musical heritage from all cultures which too often lies dormant beneath our "top-40" consciousnesses.

The head of the music department at Soumi College, Mel has also written compositions for the kantele and orchestra, and performed them in concerts throughout America and in Europe.

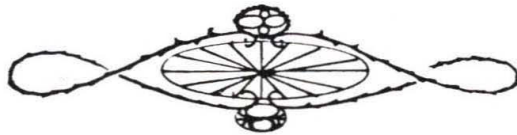

Featured Performers

Port City Bluegrass Band

Port City Bluegrass Band features Marc Conley - Banjo, Dave Sebolt - Guitar, Dan Sebolt - Fiddle, Jon Cotton - Bass. We know that you will enjoy their sweet vocals and tight instrumentals. Listen for the 3-finger banjo plucking-style which helps to distinguish "bluegrass" music from other old-time music types.

Terry Lee Hale & Becca Sarow

Two of our most popular performers all rolled up into one act, Becca and Terry are coming to us this year from way out west in Colorado. Their music is a fusion of Chicago and Texas blues, a style they've labeled "Chi-tex."

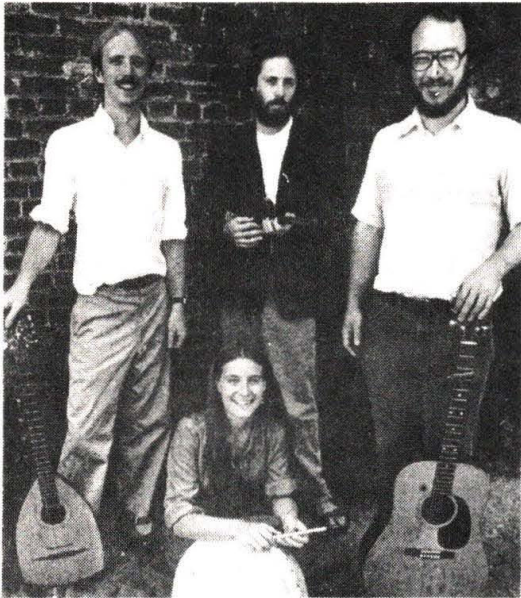

Walking on Air

WALKING ON AIR, a band hailing from the Twin Cities area, describes its music as "2/3 accompanied songs of Irish, Scottish and English sources, and 1/3 dance music in Irish and Scottish tradition." Its four members are Jamie Gans, on fiddle, viola and whistle; Michelle Delattre on dulcimer and whistle; Don Clark - bouzouki, mandolin and guitar; and Ross Sutter on guitar and bodhran - the latter three members also providing the vocals.

Joel Mabus

While the "traditional roots" for most of us only go back as far as old "Peter, Paul and Mary" albums, Joel Mabus can legitimately look to four generations worth of heritage within his own family. That's a whole lot of legacy to live up to, but Joel meets the challenge superbly with virtuoso skills on guitar, banjo, mandolin and fiddle. Adept at quite a number of musical styles, his forthcoming second album, "settin' the Woods on Fire" (Flying Fish) should not only offer new tunes, but new dimensions as well.



Robin & Linda Williams

It was inevitable that Robin and Linda Williams and the Hiawatha Music Co-op would come together since one of their songs is featured in the September, 1979 edition of "Sing Out!" - just a few pages away from the article on us. The song, entitled "Step It Out Nancy" is typical of their style - featuring a contemporary piece with a new twist to the moral, yet still true to traditional forms in its rendering.

Sally Rogers

Star of our first-ever H.M.C. Student Chapter Concert, Sally had to “face-off” against the entire N.M.U. hockey squad in drawing an audience that April evening, but then, that’s the sort of ‘plucky’ gal that she is. Her first album, released shortly thereafter, has proved tremendously successful, and with good reason - it’s simply one of the finest recordings - of any category - to be found today.



Eclectricity

“ECLECTRICITY” is a three-member group which makes its ‘ohm’ in the Bloomington, Indiana area. That “c” in the name, which doesn’t quite seem to fit, is for “eclectic” - meaning “put together from many sources” which collectively include experience in folk, rock, bluegrass, swing, orchestral, and chamber music, as well as Indian music forms and instruments. The male members, Bob Lucas and Bill Schwarz, have been performing together for over 17 years, while Miriam Sturm has been playing violin since the age of nine.

Roustabout String Band

It’s been said that the “Roustabout String Band” makes a lot of music for a four-piece band! Its personnel: Tom T. Ball on bass; Peter Humphreys on guitar; and Bruce and Diane Zeeuw on banjo and fiddle respectively, play a variety of musical sounds ranging from old-time fiddle tunes to jug band music, early swing, and blues. They have been together in their present form for about three years. This marks the second time that they’ve appeared for us, having headlined our November Concert last year.

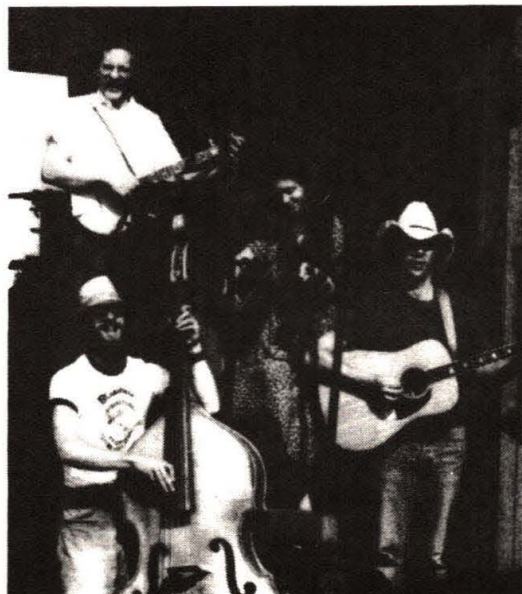

The workshops at Stages 1 and 2 are presentations offered by the performers on various musicians in an informal atmosphere.

Audience participation is encouraged in the two dance workshops.

At the Workshop Tent performers will demonstrate, discuss, and instruct people interested songs with others, too.

SATURDAY'S SCHEDULE

12:00 - 1:00

STAGE ONE

AMERICAN REGIONAL
MUSICAL STYLES

*Howie Tarnower, Alan
Senauke, Frank Youngman,
Robin & Linda Williams,
Gerald Ross, Dave Ross

STAGE TWO

FOLK DANCING

Marquette Folk Dancers

WORKSHOP TENT

FLAT-PICKING GUITAR

Joel Mabus, Marcy Marxer

1:00 - 2:00

WOMAN-MADE MUSIC

*Sally Rogers, Sue Hammond,
Becca Sarow, Marcy Marxer,
Diane Zeeuw, Karrie Potter

UNCOMMON

INSTRUMENTS

*Bill Schwarz, Don Clark,
Gogebic Range Tamburitians

OLD-TIME BANJO

Melanie Kennicott,
Jim Sigler, Bruce Zeeuw

2:00 - 3:00

CLOGGING

*Costa-Bella Cloggers,
Frank Youngman, and
the Spontaneous Stringband

EASTERN EUROPEAN
MUSIC

*Bob Lucas, Bill Schwarz,
Miriam Sturm, Gogebic Range
Tamburitians

DULCIMER

Sally Rogers

3:00 - 4:00

BLUES, RAG & SWING

*Frank Youngman, Joel
Mabus, Gerald Ross, Terry
Lee Hale, Becca Sarow,
Bob Lucas

CHILDRENS SING-A-
LONG

*Sue Hammond, Sally
Rogers, Dave Ross, Alan
Senauke, Howie Tarnower,
Marcy Marxer

BLUEGRASS BANJO

Marc Conely,
Bruce Irving

4:00 - 5:00 – OPEN MIKE

5:10 – CONCERTS BEGIN

SATURDAY CONCERTS

5:10 - 5:40 – Gogebic Range Tamburitians

5:50 - 6:20 – Julie Saccone

6:30 - 7:10 – Close To The Floor

7:20 - 8:00 – Joel Mabus

8:10 - 8:50 – Walking On Air

9:00 - 9:40 – Robin and Linda Williams

9:50 - 10:30 – Roustabout Stringband - and the Costa-Bella Cloggers

10:40 - 11:20 – Terry Lee Hale and Becca Sarow

11:30 - 12:10 – Port City Bluegrass

12:20 - 1:00 – Lost World Stringband - and the Costa-Bella Cloggers

themes and instruments. These workshops give the audience an opportunity to hear the

ed in different instruments. It's a good opportunity to share your tunes, techniques, and

SUNDAY'S SCHEDULE

11:00 - 12:00

STAGE ONE
GOSPEL SING

All performers invited

STAGE TWO

WORKSHOP TENT

12:00 - 1:00

REEDS & BELLOWS

*Gerald Ross, Frank
Youngman, Bill Schwarz,
Paul Winder, Dick Swain

BALLADS

*Robin & Linda Williams,
Alan Senauke, Howie
Tarnower, Karrie Potter,
Ross Sutter

ADVANCED CLOGGING

Costa-Bella Cloggers and the
New Spontaneous String-
band

1:00 - 2:00

HARMONY

*Sally Rogers, Karrie Potter
Alan Senauke, Howie
Tarnower, Robin and
Linda Williams

FIDDLE STYLES

*Jamie Gans, Paul Winder,
Miriam Sturm, Dave Ross,
Dan Sebolt, Steve Sleight

HOMEMADE MUSIC

Cracklin' Sap Stompers

2:00 - 3:00

BRITISH ISLES SONGS
AND TUNES

*Karrie Potter, Jamie Gans,
Michelle Delattre,
Ross Suttles, Don Clark,
Paul Winder

NONSENSE

*Frank Youngman,
Gerald Ross, Sally Rogers,
Marcy Marxer,
Jack Bowers

SONGWRITING

WORKSHOP
Terry Lee Hale and
Becca Sarow

3:00

CONCERTS BEGIN

SUNDAY CONCERTS

3:00 - 3:30 — Bear Creek

3:40 - 4:10 — Mel Kangas

4:20 - 4:50 — Cracklin' Sap Stompers

5:00 - 5:30 — Boreal Stringband

5:40 - 6:20 — Sally Rogers

6:30 - 7:10 — Fiction Brothers

7:20 - 8:00 — Bosom Buddies and the Costa-Bella Cloggers

8:10 - 8:50 — Eclectrlicity

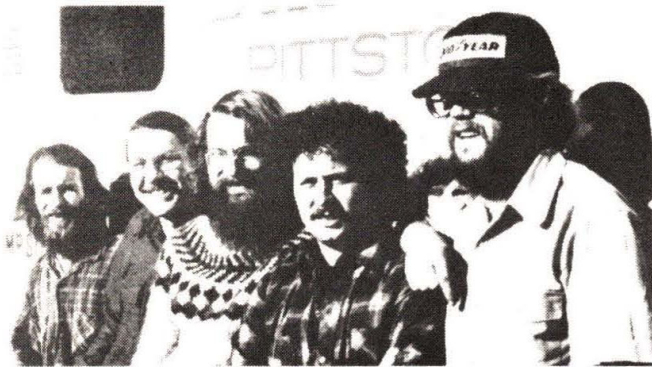

Lost World String Band

They were there at the beginning of the Co-op, folks, helping us get our feet off the ground in more ways than one! Members are from left to right in photo: "Mayor" Dave Ross, Stan Werbin, Paul

Winder, and Gerald (no relation) Ross (that's 'Coon, a.k.a. Frank Youngman, on the end). Appearing under our banner for the fourth time now, those of you who haven't seen 'em since the "button accordion revolution" are in for some surprises!

Bosom Buddies

Though this band has been together for no longer than certain music co-ops we could name, their vitality is winning over new fans for them so fast that it's hard to keep abreast of their activities these days (. . .sorry). The

BUDDIES are: Sue Hammon on fiddle; Melanie ("Mel") Kennicott on banjo; and Marcy Marxer and Karrie Potter, who interchange on combinations of guitar/mandolin. Specializing in old-time music of the early 1900's, the BUDDIES manage to breathe new life into every rendition they perform.



The Fiction Brothers

Comprised of Alan Senauke and Howie Tarnower, the "brotherhood" is actually fictional, yet the closeness of their vocal and instrumental blendings conveys a great familial bonding. In addition to performing, Howie is the proprietor of

the Flashing Fingers School of Folk Music in Ithaca, N.Y., while Alan is a contributing editor for "Sing Out!" Magazine.

The Costa Bella Cloggers

Inspired by the Green Grass Cloggers one hot, starry night, twelve (more or less) pairs of highly-evolved feet got to square dancing and clogging. They loved it. Time passed.

Presently, its members are (pictured from right to left): Red LeClear, Peaches Burke, Ken Koblarz, Jan Goffnett, Jon Cotton, Chris Cooley, Dave Goodwin and Barb Hunter. Other (camera-shy) members include: Marcia LeClear, Donna Myers, Kris and Steve Rose, and Tom T. Ball. The one motto that these dedicated dancers live by - "Feet, don't fail me now!"

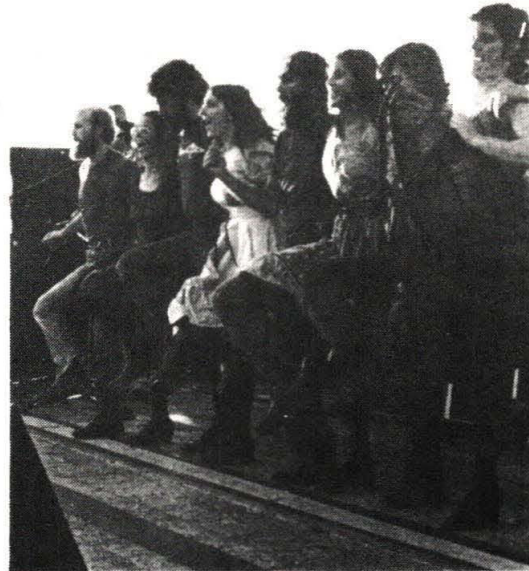

Gogebic Range Tamburitians

Named for the tamburitza - the national instrument of Yugoslavia - as well as for the geographic region of their western-U.P./northern Wisconsin homes, the GOGEBIC RANGE TAMBURITZANS have been sharing the color and excitement of their folk heritage with regional audiences for a dozen years now. The 11 musicians and dancers provide a living example of the richness of their native culture.



Star Rt., Box 728
Deerton, Michigan 49822
Phone: 906-343-6787



SUNWOOD ENERGIES

"YOUR OTHER UTILITY COMPANY"

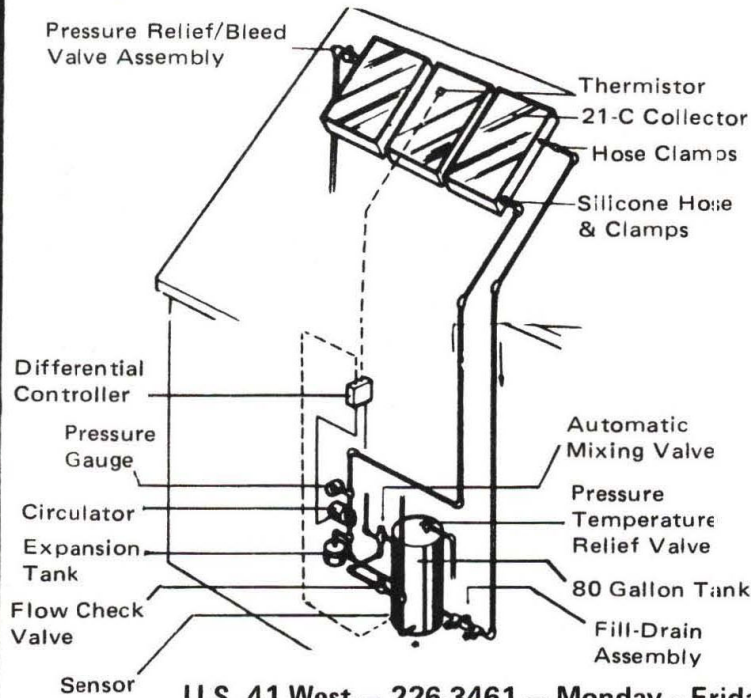

ALL ELECTRIC HOMEOWNERS:

Your approximate cost for electric hot water is \$30 per month x 12 mo. = \$360 per year.

SUNWOOD can now reduce that to about \$50 per year.

Your approximate space heating costs are about \$1500 per year.

SUNWOOD can now reduce that to \$200 per year or less.

Call us now and find out about a solar woodstove interface and 65% tax credit on your system.

DON'T PASS THIS UP!

FROM ONE
BEER LOVER
TO
ANOTHER...

WELCOME TO THE
 SECOND ANNUAL HIAWATHA
 TRADITIONAL AMERICAN MUSIC FESTIVAL



University Shopping Center
 N. Third Street - 225-1834



Woodstove Dealer



LOW PRICES
 TOP QUALITY



PLUS MUCH MORE!

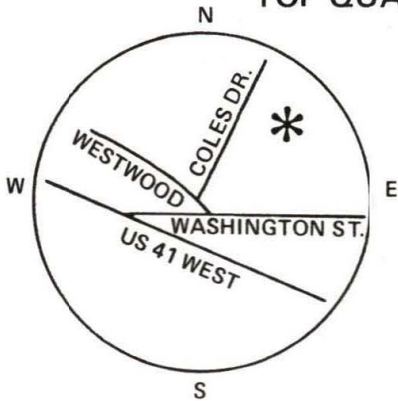

- * Booklets
- * Business cards
- * Business forms
- * Carbonless paper
- * Envelopes
- * Fliers
- * Posters
- * Menus
- * Post cards
- * Resumes
- * Statements
- * Labels



WEDDING INVITATIONS
 XEROX COPYING

228-6610

104 Coles Drive, Marquette, MI 49855
 OPEN MON. - FRI. 8:30 a.m. - 5:00 p.m.

Jim Sigler

Private Lessons on
GUITAR - MANDOLIN
BANJO - FIDDLE
DOBRO - DULCIMER

For Beginning to
Intermediate Students

Four years teaching experience at the Elderly Instruments School of Folk Music in East Lansing. Jim is formerly with the Lost World String Band and performs locally with The Boreal String Band and Frosty Morn.

MARQUETTE
228-6849

weaving
silk screening
commercial design
calligraphy

ANNIE WORTHMAN
SAND RIVER, MICH.

906-343-6626

custom clothing by
Rumpelstiltsken



426 Baraga * Marquette, Michigan -
906-226-3658

Folkwear clothing * Embroidering
Quilts * Soft sculpture * Gumbies
Patching

OZONE OF THE NORTH

Marquette's Family Waterbed Store

- * Waterbeds
- * Frames
- * Heaters
- * Covers
- * Liners

Single to King Size
Wide Selection of Records
and Tapes
Imported Clothing — Jewelry

We accept VISA and Mastercharge

226-3413
215 S. Front, Marquette

Calendar of Upcoming Events

8/30-31	Great River Traditional Music and Crafts Festival	Fred Starner 1409 State Street LaCrosse, WI 54601
9/5-6-7	7th Wheatland Old-Time and Bluegrass Festival	Wheatland Music Organization Remus, MI 49340
9/12	ART THIEME IN CONCERT AT N.M.U.	Jamrich Hall Room 102 Northern Michigan University Hiawatha Student Chapter
9/12-13-14	Equinox Festival	c/o 306 N. Brooks Madison, WI 53715
9/27	SWEET CORN IN CONCERT AT VISTA THEATRE IN NEGAUNEE	Vista PAAC Theatre 218 Iron Street Negaunee, MI 49866 or Hiawatha Music Co-op
9/27-28	Ocooch Mt. Festival	Emily Osborne Gillingham, WI 54633
10/28	DE DANANN IN CONCERT AT N.M.U.	Great Lakes Rooms University Center Northern Michigan University Hiawatha Student Chapter
11/14	DAKOTA DAVE HULL and SEAN BLACKBURN IN CONCERT AT N.M.U.	Jamrich Hall Room 103 Northern Michigan University Hiawatha Student Chapter
12/Date Not Confirmed	AIRFLOW DELUX IN CONCERT AT N.M.U.	Location Not Confirmed Northern Michigan University Hiawatha Student Chapter

